

P012...R PX12...R
P016...R PX16...R
P020...R PX20...R

PHOENIX CAM SWITCHES WITH TYPE "R" PANEL MOUNTING (12 A / 16 A / 20 A)

CODE READING 2
SPECIFICATIONS 3
OVERALL DIMENSIONS..... 6
ELECTRICAL SCHEMES..... 8
ACTUATORS 15
MOUNTING INSTRUCTIONS 17



Before use, read this booklet carefully to acquaint yourself with the features of the product. This booklet is an integral part of the product and therefore must be kept until the product is dismissed.



Giovenzana International B.V. reserves the right to change the features and data shown in this document at any time and without notice. This document cannot therefore be considered a contract with third parties.



P0 and PX series cam switches are designed and manufactured according to IEC international standard and EN European regulations.



Any improper installation or any tampering of the device may cause serious personnel injury or property damage, therefore, the installation and maintenance must be performed by specialized and authorized personnel.



The use of this device is not allowed in environment with a potentially explosive atmosphere or in presence of corrosive substances and in salt spray.

ATTENTION
Before any installation or maintenance operation, disconnect the power supply to the system. Before restoring the power supply, make sure that all connections to the device have been made correctly. Giovenzana International B.V. disclaims any responsibility for any damage to things and people caused by non-compliance with the rules described here.

Cam switches involved in this instruction manual:

Series	Mounting	Terminal protection class	AC-21A (690 V)	AC-23A (400 V)
P012...R	Rear panel	IP20	12 A	10 A
P016...R			16 A	14 A
P020...R			20 A	16 A
PX12...R	Rear panel	IP10	12 A	10 A
PX16...R			16 A	14 A
PX20...R			20 A	16 A

Read the page with the code reading for further useful information on the product in your possession. This instruction manual illustrates features and procedures relating to the products in the Giovenzana catalog. The specifications on p.3 and the mounting instructions on p.17 and following, are also valid for custom products derived from one of the series illustrated in this manual.

CODE READING

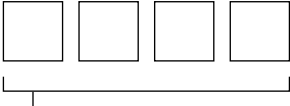

Series

Specifications: p.3

P012	12 A, IP20 contacts
P016	16 A, IP20 contacts
P020	20 A, IP20 contacts
PX12	12 A, IP10 contacts
PX16	16 A, IP10 contacts
PX20	20 A, IP10 contacts

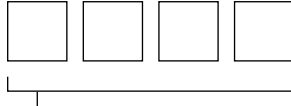

Electrical scheme

Reference table: p.8

	ON-OFF switches 0-1
0001	1 pole
0002	2 poles
0003	3 poles
0004	4 poles
0005	5 poles
0006	6 poles
0007	3 poles with spring return to zero
	Changeover switches 1-0-2
0008	1 pole
0009	2 poles
0010	3 poles
0011	4 poles
	Motor switches
0012	Reversing switch 3 poles
0013	Reversing switch 3 poles with spring return to zero
0014	Dahlander pole changing two speed switch
0015	Star-Delta starter switch
0016	Reversing switch single phase with centrifugal cut-out
0031	Reversing-Dahlander pole changing two speed switch
0017	Starter switch single phase with auxiliary phase
0018	Reversing-starter switch single phase with auxiliary phase
	Ammeter and voltmeter switches
0019	Ammeter selector switch 1 pole for 3 current transformers
0020	Voltmeter selector switch phase-neutral
0021	Voltmeter selector switch phase-phase
0022	Voltmeter selector switch phase-phase for two circuits
0023	Voltmeter selector switch phase-phase and phase-neutral
0024	Voltmeter selector switch phase-phase and 1 phase-neutral
	Step switches
0025	Step switch 1-2 positions without zero 1 pole
0026	Step switch 1-2 positions without zero 2 poles
0027	Step switch 1-2 positions without zero 3 poles
0038	Step switch 1-2-3 positions without zero 1 pole
0039	Step switch 1-2-3 positions without zero 2 poles
0040	Step switch 1-2-3 positions without zero 3 poles
0041	Step switch 1-2-3-4 positions without zero 1 pole
0042	Step switch 1-2-3-4 positions without zero 2 poles
0043	Step switch 1-2-3-4 positions without zero 3 poles
0028	Step switch 0-1-2 positions with zero 1 pole
0032	Step switch 0-1-2 positions with zero 2 poles
0033	Step switch 0-1-2 positions with zero 3 poles
0029	Step switch 0-1-2-3 positions with zero 1 pole
0034	Step switch 0-1-2-3 positions with zero 2 poles
0035	Step switch 0-1-2-3 positions with zero 3 poles
0030	Step switch 0-1-2-3-4 positions with zero 1 pole
0036	Step switch 0-1-2-3-4 positions with zero 2 poles
0037	Step switch 0-1-2-3-4 positions with zero 3 poles



Cam switch mounting type

Overall dimensions: p.6

R	rear panel mounting
S	custom product (these products have their own electrical scheme, not available in this document)

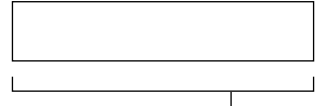

Actuator code

Each cam switch series can be fitted with one or more actuators with their own code. This document provides the installation instructions for each cam switch series and its matching actuators. Actuators reference table: p.15

SPECIFICATIONS

General characteristics

Protection class	control	EN 60529 UL50 / NEMA	IP65 Type 1 - 4 - 4X
	control with knob only		IP40
	terminals		P012... / P016... / P020... PX12... / PX16... / PX20... IP20 IP10
Material group		EN 60947-1	II
Pollution grade		EN 60947-1	3
Flammability		UL94	V0 (live electrical parts)
Ambient temperature	operating		-40 ... +85°C
	storage		-40 ... +70°C
Climate withstand		IEC 68 part 2-3 IEC 68 part 2-30	damp heat, steady state damp heat, cyclic
Terminal screw identification	conforming to		EN50013
Connections	terminal block caliber	EN60947-1	A3
	terminal screw		M3.5
	tightening torque	EN60947-1 UL508	0.8 N·m (7.2 lb·in) 7.5 lb·in (0.85 N·m)
Connectable section	flexible conductors		1 × 0.75 ... 4 mm ² or 2 × 0.75 ... 2.5 mm ² AWG 18 ... 10
	solid conductors		1 × 0.75 ... 4 mm ² or 2 × 0.75 ... 2.5 mm ² AWG 18 ... 10
Contacts			double breaking
Opening angles			30° - 45° - 60° - 90°
Mechanical lifetime	@ 120 operations / hour		1 million cycles
Electrical lifetime	@ 120 operations / hour		P012... / PX12... 1 million cycles P016... / PX16... 0.75 million cycles P020... / PX20... 0.75 million cycles

EN 60947-3 characteristics

		P012... / PX12...	P016... / PX16...	P020... / PX20...
Rated operating voltage	U _e	690 V	690 V	690 V
Rated insulation voltage	U _i	690 V	690 V	690 V
Rated impulse withstand voltage (sectionable)	U _{imp}	4 kV	4 kV	4 kV
Rated thermal current	I _{th}	16 A	20 A	25 A
Rated enclosed thermal current	I _{the}	12 A	16 A	20 A
Frequency		50/60 Hz	50/60 Hz	50/60 Hz

Alternate current

Rated operating current		le		P012... / PX12...	P016... / PX16...	P020... / PX20...			
AC-21A	Switching of resistive loads, including moderate overloads		690 V	12 A	16 A	20 A			
AC-22A	Switching of mixed resistive and inductive loads, including moderate overloads		690 V	12 A	16 A	20 A			
AC-23A	Switching of motor loads or other highly inductive loads	1 phase - 1 pole	110 V	12 A	1.1 kW	14 A	1.5 kW	18 A	2 kW
			230 V	12 A	2.2 kW	14 A	3 kW	18 A	4 kW
		3 phases - 3 poles	230 V	10 A	3 kW	14 A	3 kW	16 A	5 kW
			400 V	10 A	5.5 kW	14 A	7.5 kW	16 A	9 kW
			500 V	10 A	7.5 kW	14 A	10 kW	16 A	11 kW
690 V	10 A	7.5 kW	14 A	10 kW	16 A	12.5 kW			
AC-3	Squirrel-cage motors: starting, switches off motors during running time	1 phase - 1 pole	110 V	10 A	0.75 kW	12 A	1.1 kW	16 A	1.5 kW
			230 V	10 A	2 kW	12 A	2.2 kW	16 A	3.5 kW
		3 phases - 3 poles	230 V	8 A	2.2 kW	10 A	3 kW	12 A	4 kW
			400 V	8 A	4 kW	10 A	5 kW	12 A	6 kW
			500 V	8 A	5.5 kW	10 A	7.5 kW	12 A	8 kW
690 V	6 A	5.5 kW	8 A	7.5 kW	10 A	9 kW			
AC-23A	Nominal breaking capacity (cosφ 0.45)		230 V	80 A	104 A	128 A			
			400 V	80 A	104 A	128 A			
			500 V	80 A	112 A	128 A			
			690 V	80 A	112 A	128 A			
Power dissipation for each pole				0.3 W	0.35 W	0.4 W			

Direct current

Rated operating current		le		P012... / PX12...	P016... / PX16...	P020... / PX20...
DC-21A	Switching resistive loads with light overloads	1 phase	50 V	10 A	12 A	16 A
DC-22A	Switching resistive loads with light overloads	1 phase	30 V	8 A	10 A	12 A

Short circuit characteristics

		P012... / PX12...	P016... / PX16...	P020... / PX20...
Rated short-time short circuit withstand current (1 s)	l _{cw}	300 A	300 A	300 A
Rated short circuit making capacity	l _{cm}	1200 A	1200 A	1200 A
Conditional rated short circuit withstand current		5 kA	5 kA	5 kA
Fuse rating (type gG)	690 V	20 A	20 A	20 A

UL 508 characteristics

		P012... / PX12...		P016... / PX16...		P020... / PX20...	
General use	600 V AC	12 A		16 A		20 A	
Standard motor load	1 phase - 2 poles	120 V AC	0.5 HP 9.8 FLA	1 HP 16 FLA	1.5 HP 20 FLA	1.5 HP 20 FLA	2 HP 12 FLA
		240 V AC	1 HP 8 FLA	1.5 HP 10 FLA	2 HP 12 FLA		
	3 phases - 3 poles	200 V AC	1.5 HP 6.9 FLA	3 HP 11.04 FLA	5 HP 17.5 FLA	5 HP 17.5 FLA	10 HP 14 FLA
		240 V AC	3 HP 9.6 FLA	5 HP 15.2 FLA	5 HP 15.2 FLA	10 HP 14 FLA	10 HP 11 FLA
		480 V AC	5 HP 7.6 FLA	7.5 HP 11 FLA	10 HP 14 FLA		
		600 V AC	5 HP 6.1 FLA	7.5 HP 9 FLA	10 HP 11 FLA		

Marking

Compliance by passed test



Approved



OVERALL DIMENSIONS

P012...R / P016...R / P020...R

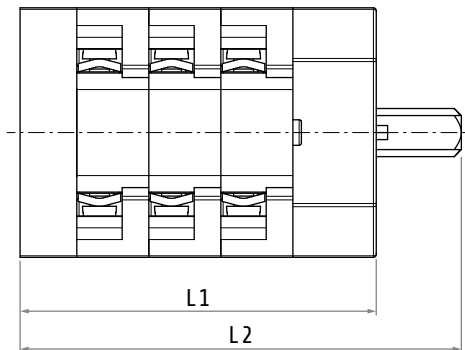
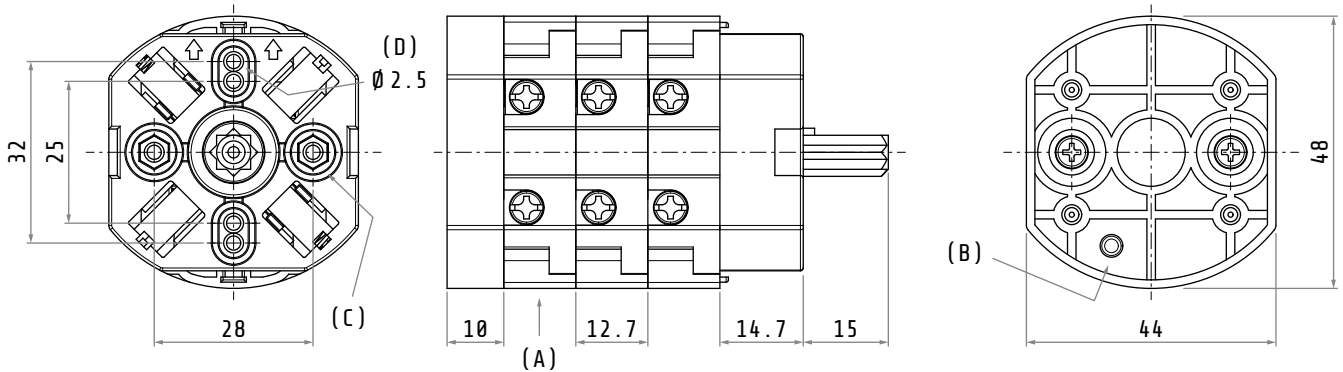

Dimensions in mm
Illustrations NOT in scale

- (A) wafer (thickness = 12.7 mm)
- (B) reference notch
- (C) metric screw (M3) fixing hole
- (D) self tapping screw (Ø 3.2) fixing hole

Some dimensions depend on the number of wafers of the cam switch and can be calculated with these formulas:

$$L1 \text{ [mm]} = 10 + (12.7 \times \text{n. of wafers}) + 14.7$$

$$L2 \text{ [mm]} = L1 + 15$$

Examples:

n. of wafers	1	2	3	4	5	6
L1 [mm]	37.4	50.1	62.8	75.5	88.2	100.9
L2 [mm]	52.4	65.1	77.8	90.5	103.2	115.9

PX12...R / PX16...R / PX20...R

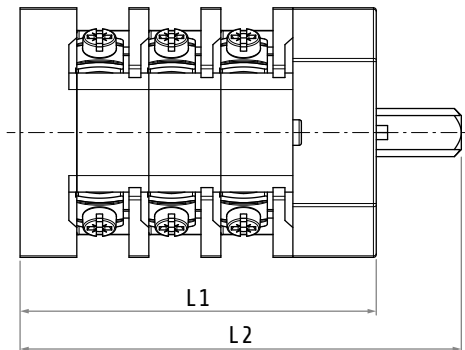
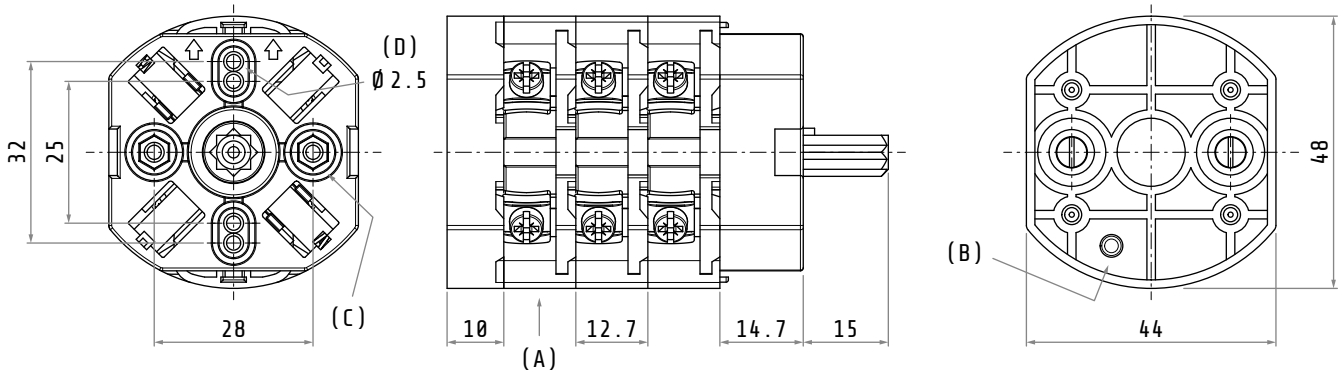

Dimensions in mm
Illustrations NOT in scale

- (A) wafer (thickness = 12.7 mm)
- (B) reference notch
- (C) metric screw (M3) fixing hole
- (D) self tapping screw (Ø 3.2) fixing hole

Some dimensions depend on the number of wafers of the cam switch and can be calculated with these formulas:

$$L1 \text{ [mm]} = 10 + (12.7 \times \text{n. of wafers}) + 14.7$$

$$L2 \text{ [mm]} = L1 + 15$$

Examples:

N. of wafers	1	2	3	4	5	6
L1 [mm]	37.4	50.1	62.8	75.5	88.2	100.9
L2 [mm]	52.4	65.1	77.8	90.5	103.2	115.9

ELECTRICAL SCHEMES

Code checking pattern

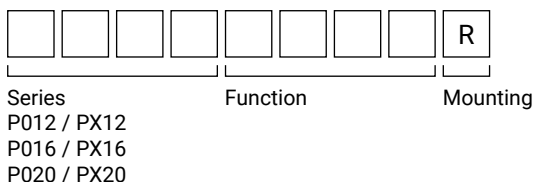

Function	N. of wafers	Electrical scheme
ON-OFF switches 0-1		
0001 ON-OFF switch 1 pole	1	p.9
0002 ON-OFF switch 2 poles	1	
0003 ON-OFF switch 3 poles	2	
0004 ON-OFF switch 4 poles	2	
0005 ON-OFF switch 5 poles	3	
0006 ON-OFF switch 6 poles	3	
0007 ON-OFF switch 3 poles with spring return to zero	2	
Changeover switches 1-0-2		
0008 Changeover switch 1 pole	1	p.9
0009 Changeover switch 2 poles	2	
0010 Changeover switch 3 poles	3	
0011 Changeover switch 4 poles	4	
Motor switches		
0012 Reversing switch 3 poles	3	p.10
0013 Reversing switch 3 poles with spring return to zero	3	
0014 Dahlander pole changing two speed switch	4	
0015 Star-Delta starter switch	4	
0016 Reversing switch single phase with centrifugal cut-out	3	
0031 Reversing-dahlander pole changing two speed switch	6	
0017 Starter switch single phase with auxiliary phase	2	
0018 Reversing-starter switch single phase with auxiliary phase	3	
Ammeter and voltmeter switches		
0019 Ammeter selector switch 1 pole for 3 current transformers	3	p.11
0020 Voltmeter selector switch phase-neutral	2	
0021 Voltmeter selector switch phase-phase	2	
0022 Voltmeter selector switch phase-phase for two circuits	4	
0023 Voltmeter selector switch phase-phase and phase-neutral	3	
0024 Voltmeter selector switch phase-phase and 1 phase-neutral	3	
Step switches		
0025 Step switch 1-2 positions without zero 1 pole	1	p.12
0026 Step switch 1-2 positions without zero 2 poles	2	
0027 Step switch 1-2 positions without zero 3 poles	3	
0038 Step switch 1-2-3 positions without zero 1 pole	2	
0039 Step switch 1-2-3 positions without zero 2 poles	3	
0040 Step switch 1-2-3 positions without zero 3 poles	5	
0041 Step switch 1-2-3-4 positions without zero 1 pole	2	
0042 Step switch 1-2-3-4 positions without zero 2 poles	4	
0043 Step switch 1-2-3-4 positions without zero 3 poles	6	
0028 Step switch 0-1-2 positions with zero 1 pole	1	
0032 Step switch 0-1-2 positions with zero 2 poles	2	
0033 Step switch 0-1-2 positions with zero 3 poles	3	
0029 Step switch 0-1-2-3 positions with zero 1 pole	2	
0034 Step switch 0-1-2-3 positions with zero 2 poles	3	
0035 Step switch 0-1-2-3 positions with zero 3 poles	5	
0030 Step switch 0-1-2-3-4 positions with zero 1 pole	2	
0036 Step switch 0-1-2-3-4 positions with zero 2 poles	4	
0037 Step switch 0-1-2-3-4 positions with zero 3 poles	6	

ON-OFF switches 0-1

0001 • 1 pole

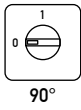

1				
	1-2			x
W	CNT	0		1

0002 • 2 poles

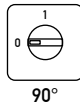

1	3-4			x
	1-2			x
W	CNT	0		1

0003 • 3 poles

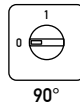

2				
	5-6			x
1	3-4			x
	1-2			x
W	CNT	0		1

0004 • 4 poles

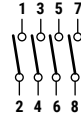
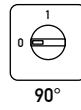

2	7-8			x
	5-6			x
1	3-4			x
	1-2			x
W	CNT	0		1

0005 • 5 poles

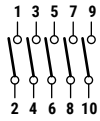
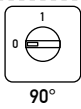

3				
	9-10			x
2	7-8			x
	5-6			x
1	3-4			x
	1-2			x
W	CNT	0		1

0006 • 6 poles

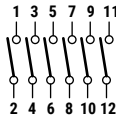
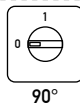

3	11-12			x
	9-10			x
2	7-8			x
	5-6			x
1	3-4			x
	1-2			x
W	CNT	0		1

0007 • 3 poles with spring return to zero

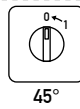

2				
	5-6			x
1	3-4			x
	1-2			x
W	CNT	0		1

Changeover switches 1-0-2

0008 • 1 pole

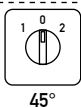

1	3-4			x
	1-2	x		
W	CNT	1	0	2

0009 • 2 poles

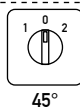

2	7-8			x
	5-6	x		
1	3-4			x
	1-2	x		
W	CNT	1	0	2

0010 • 3 poles

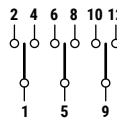
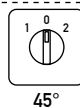

3	11-12			x
	9-10	x		
2	7-8			x
	5-6	x		
1	3-4			x
	1-2	x		
W	CNT	1	0	2

0011 • 4 poles

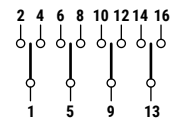
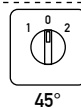

4	15-16			x
	13-14	x		
3	11-12			x
	9-10	x		
2	7-8			x
	5-6	x		
1	3-4			x
	1-2	x		
W	CNT	1	0	2

Motor switches

0012 • Reversing switch 3 poles

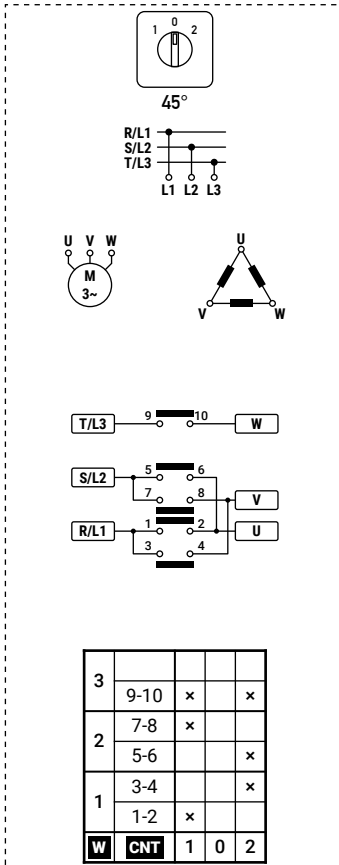

0013 • Reversing switch 3 poles with spring return to zero

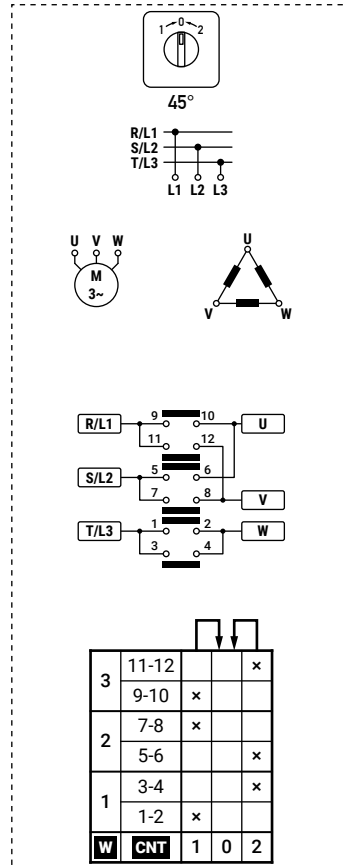

0014 • Dahlander pole changing two speed switch

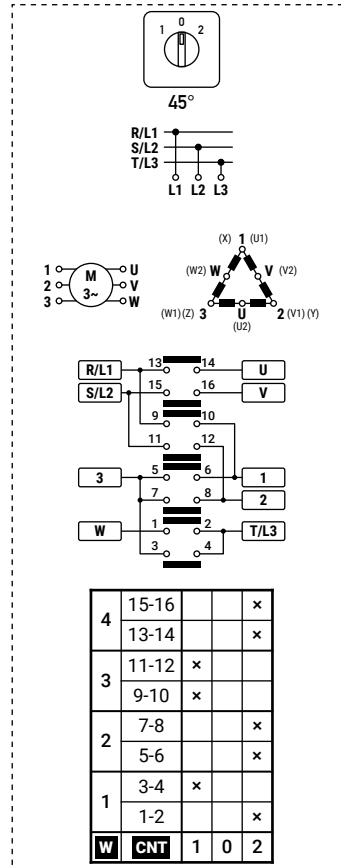

0015 • Star-Delta starter switch

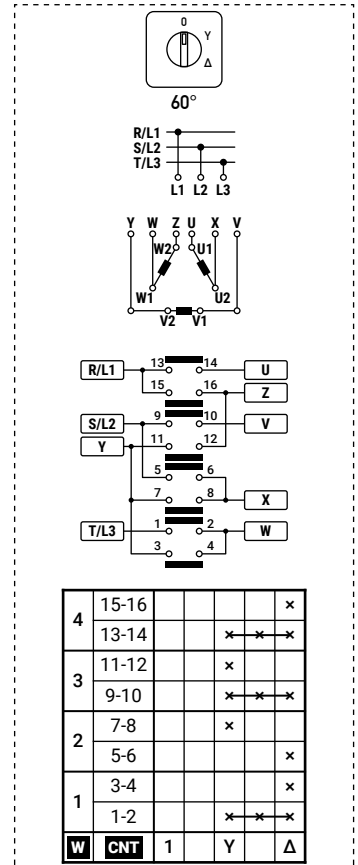

0016 • Reversing switch single phase with centrifugal cut-out

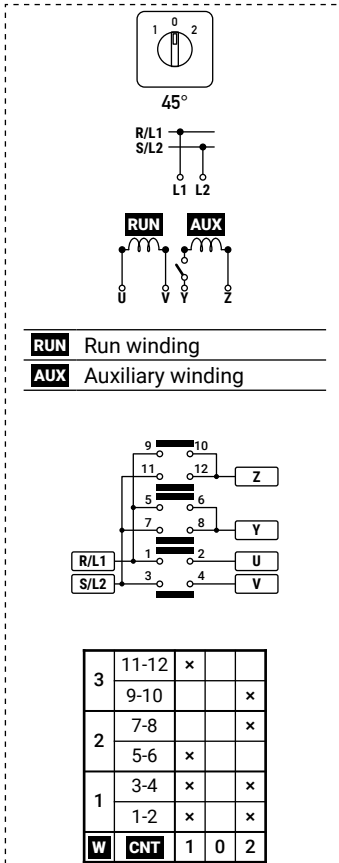

0031 • Reversing-Dahlander pole changing two speed switch

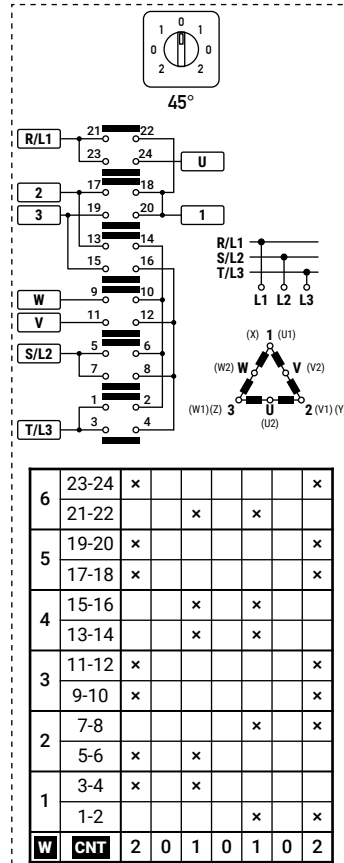

0017 • Starter switch single phase with auxiliary phase

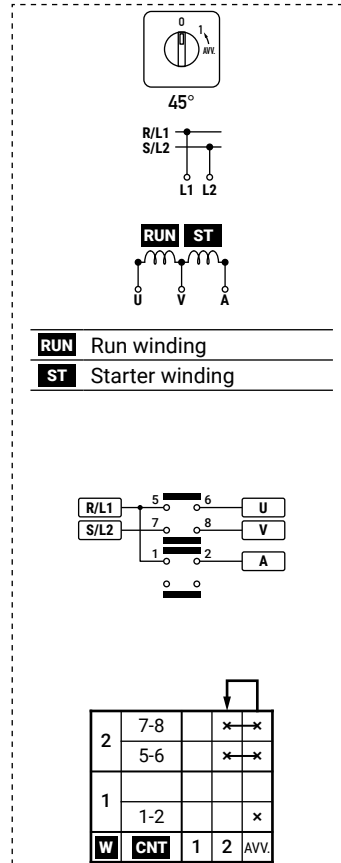

0018 • Reversing-starter switch single phase with auxiliary phase

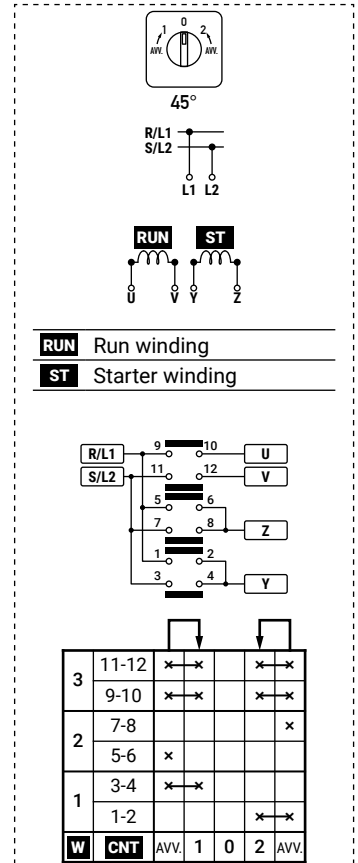

Ammeter and voltmeter switches

1/1

0019 • Ammeter selector switch
1 pole for 3 current transformers

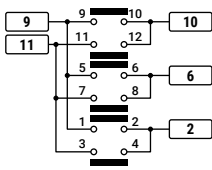
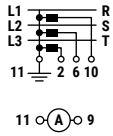
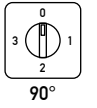

3	11-12	x	x	x	x	x	x
	9-10		x	x	x		
2	7-8	x	x	x	x	x	x
	5-6			x	x	x	
1	3-4	x	x	x	x	x	x
	1-2					x	x
W	CNT	0	1	2	3		

0020 • Voltmeter selector switch
switch phase-neutral

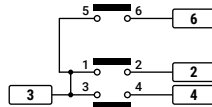
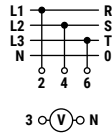
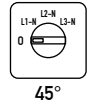

2	5-6				x
	3-4			x	
1	1-2		x		
W	CNT	1	L1-N	L2-N	L3-N

0021 • Voltmeter selector switch
switch phase-phase

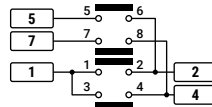
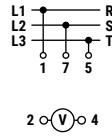
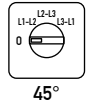

2	7-8	x	x		
	5-6			x	x
1	3-4				x
	1-2		x		
W	CNT	1	L1-L2	L2-L3	L3-L1

0022 • Voltmeter selector switch
phase-phase for two circuits

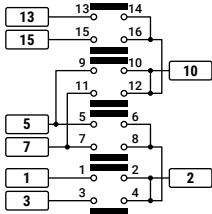
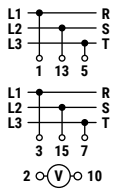
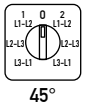

4	15-16		x	x				
	13-14				x	x		
3	11-12	x				x		
	9-10							
2	7-8		x					
	5-6				x			
1	3-4	x	x					
	1-2			x	x			
W	CNT	L3-L1	L2-L3	L1-L2	0	L1-L2	L2-L3	L3-L1
		1	2					

0023 • Voltmeter selector switch
phase-phase and phase-neutral

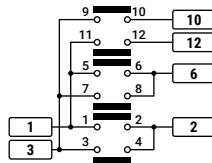
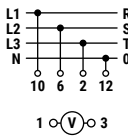
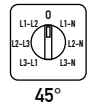

3	11-12			x	x	x		
	9-10	x	x					
2	7-8		x					
	5-6		x		x			
1	3-4	x	x					
	1-2					x		
W	CNT	L3-L1	L2-L3	L1-L2	0	L1-N	L2-N	L3-N

0024 • Voltmeter selector switch
phase-phase and 1 phase-neutral

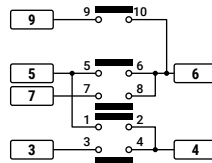
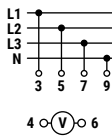
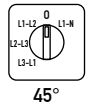

3	9-10					x
	7-8	x	x			
2	5-6		x			
	3-4	x	x	x		
1	1-2		x			
W	CNT	L3-L1	L2-L3	L1-L2	0	L1-N

Step switches

0025 • Step switch 1-2 positions without zero 1 pole

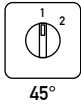

1	3-4		x
	1-2	x	
W	CNT	1	2

0026 • Step switch 1-2 positions without zero 2 poles

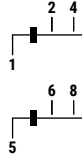
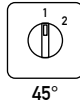

2	7-8		x
	5-6	x	
1	3-4		x
	1-2	x	
W	CNT	1	2

0027 • Step switch 1-2 positions without zero 3 poles

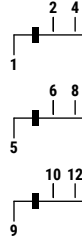
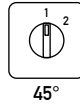

3	11-12		x
	9-10	x	
2	7-8		x
	5-6	x	
1	3-4		x
	1-2	x	
W	CNT	1	2

0038 • Step switch 1-2-3 positions without zero 1 pole

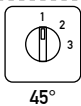

2	5-6			x
1	3-4		x	
	1-2	x		
W	CNT	1	2	3

0039 • Step switch 1-2-3 positions without zero 2 poles

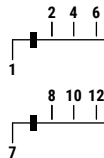
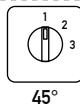

3	11-12			x
	9-10		x	
2	7-8	x		
	5-6			x
1	3-4		x	
	1-2	x		
W	CNT	1	2	3

0040 • Step switch 1-2-3 positions without zero 3 poles

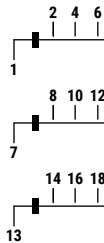
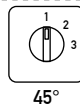

5	17-18			x
4	15-16		x	
	13-14	x		
3	11-12			x
	9-10		x	
2	7-8	x		
	5-6			x
1	3-4		x	
	1-2	x		
W	CNT	1	2	3

Step switches

2/3

0041 • Step switch 1-2-3-4 positions without zero 1 pole

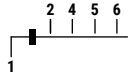
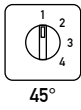

2	7-8			x	
	5-6		x		
1	3-4	x			
	1-2	x			
W	CNT	1	2	3	4

0042 • Step switch 1-2-3-4 positions without zero 2 poles

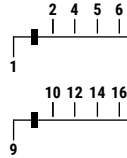
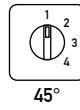

4	15-16			x	
	13-14		x		
3	11-12	x			
	9-10	x			
2	7-8			x	
	5-6		x		
1	3-4	x			
	1-2	x			
W	CNT	1	2	3	4

0043 • Step switch 1-2-3-4 positions without zero 3 poles

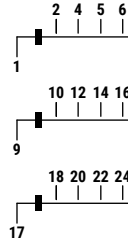
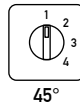

6	23-24			x	
	21-22		x		
5	19-20	x			
	17-18	x			
4	15-16			x	
	13-14		x		
3	11-12	x			
	9-10	x			
2	7-8			x	
	5-6		x		
1	3-4	x			
	1-2	x			
W	CNT	1	2	3	4

0028 • Step switch 0-1-2 positions with zero 1 pole

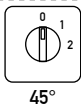

1	3-4			x
	1-2		x	
W	CNT	0	1	2

0032 • Step switch 0-1-2 positions with zero 2 poles

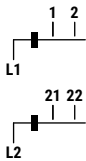
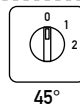

2	7-8			x
	5-6		x	
1	3-4			x
	1-2		x	
W	CNT	0	1	2

0033 • Step switch 0-1-2 positions with zero 3 poles

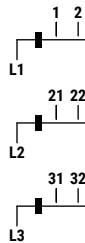
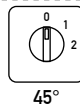

3	11-12			x
	9-10		x	
2	7-8			x
	5-6		x	
1	3-4			x
	1-2		x	
W	CNT	0	1	2

Step switches

3/3

0029 • Step switch 0-1-2-3 positions with zero 1 pole

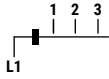
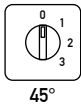

2	7-8			x	
	5-6	x			
1	1-2		x		
W	CNT	0	1	2	3

0034 • Step switch 0-1-2-3 positions with zero 2 poles

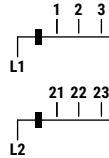
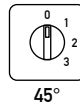

3	11-12			x	
	9-10	x			
2	7-8		x		
	5-6		x		
1	3-4			x	
	1-2	x			
W	CNT	0	1	2	3

0035 • Step switch 0-1-2-3 positions with zero 3 poles

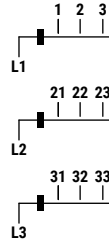
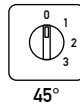

5	19-20			x	
4	15-16			x	
	13-14	x			
3	11-12			x	
	9-10	x			
2	7-8		x		
	5-6		x		
1	3-4			x	
	1-2	x			
W	CNT	0	1	2	3

0030 • Step switch 0-1-2-3-4 positions with zero 1 pole

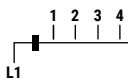
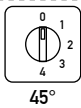

2	7-8			x		
	5-6	x				
1	3-4			x		
	1-2		x			
W	CNT	0	1	2	3	4

0036 • Step switch 0-1-2-3-4 positions with zero 2 poles

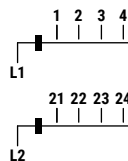
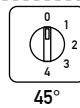

4	15-16			x		
	13-14	x				
3	11-12			x		
	9-10		x			
2	7-8			x		
	5-6	x				
1	3-4			x		
	1-2		x			
W	CNT	0	1	2	3	4

0037 • Step switch 0-1-2-3-4 positions with zero 3 poles

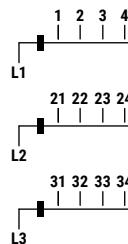
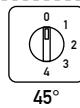









6	23-24			x		
	21-22	x				
5	19-20			x		
	17-18		x			
4	15-16			x		
	13-14	x				
3	11-12			x		
	9-10		x			
2	7-8			x		
	5-6	x				
1	3-4			x		
	1-2		x			
W	CNT	0	1	2	3	4





















ACTUATORS

















Cam switches / actuators matrix

















Check the "Operation schemes matrix" (p.16) to identify the available operation scheme for each operator. Each actuator is referenced to the relevant page of the mounting instructions.

Series and size		P012 / P016 / P020	PX12 / PX16 / PX20
Terminal protection class		IP20	IP10
Mounting type			R
48x48	Grey/Black		
screw Ø 22	IP65 IP65		001/... (p.17) 056X/... (p.18)
48x48	Yellow/Red		
screw Ø 22	IP65 IP65		002/... (p.17) 058X/... (p.18)
48x48	Grey/Black padlock in 0		
screw Ø 22	IP65 / 4-4X IP65		003/... (p.17) 059X/... (p.18)
48x48	Yellow/Red padlock in 0		
screw Ø 22	IP65 / 4-4X IP65		004/... (p.17) 060X/... (p.18)
ring	Grey/Black with knob		
Ø 22	IP65		028X * (p.19)
ring	Grey/Black with key		
Ø 22	IP65		029X * (p.19)
ring 48x48	Grey/Black with key		
Ø 22	IP65		057X/... (p.20)
67x67	Grey/Black max 3 padlocks		
screw Ø 22	IP65 / 4-4X IP65		009/... (p.21) 061X/... (p.21)
67x67	Yellow/Red max 3 padlocks		
screw Ø 22	IP65 / 4-4X IP65		010/... (p.21) 062X/... (p.21)

* These actuators do not have any operation scheme on the "Operation scheme matrix".

		ON-OFF switches 0-1			Changeover switches 1-0-2 / Motor switches					
										
		90°	90°	45°	45°	45°	45°	60°	45°	45°
	001/...	0001	0001-1	0007	0008	0017	0013	0015	0018	0031
	002/...	0001	0001-1	0007	0008	0017	0013	0015	0018	0031
	003/...	0001	0001-1	0007	0008	0017	0013	0015	0018	0031
	004/...	0001	0001-1	0007	0008	0017	0013	0015	0018	0031
	009/...	0001	0001-1	-	0008	0017	0013	0015	0018	0031
	010/...	0001	0001-1	0007	0008	0017	0013	0015	0018	0031
	056X/...	0001	0001-1	0007	0008	0017	0013	0015	0018	0031
	057X/...	0001	0001-1	0007	0008-CA	-	0013-CA	-	-	-
	058X/...	0001	0001-1	0007	0008	-	0013	-	-	-
	061X/...	0001	0001-1	0007	0008	-	0013	-	-	-
	062X/...	0001	0001-1	0007	0008	-	0013	-	-	-

		Step switches					
							
		45°	45°	45°	45°	45°	45°
	001/...	0025	0028	0038	0029	0041	0030
	002/...	-	-	-	-	-	-
	003/...	-	-	-	-	-	-
	004/...	-	-	-	-	-	-
	009/...	-	-	-	-	-	-
	010/...	-	-	-	-	-	-
	056X/...	0025	0028	0038	0029	0041	0030
	057X/...	-	0028-CA	-	0029-CA	-	-
	058X/...	-	-	-	-	-	-
	061X/...	-	-	-	-	-	-
	062X/...	-	-	-	-	-	-

		Amm. switches	Voltmeter switches				
							
		90°	45°	45°	45°	45°	45°
	001/...	0019	0020	0021	0022	0023	0024
	002/...	-	-	-	-	-	-
	003/...	-	-	-	-	-	-
	004/...	-	-	-	-	-	-
	009/...	-	-	-	-	-	-
	010/...	-	-	-	-	-	-
	056X/...	0019	0020	0021	0022	0023	0024
	057X/...	-	-	-	-	-	-
	058X/...	-	-	-	-	-	-
	061X/...	-	-	-	-	-	-
	062X/...	-	-	-	-	-	-

MOUNTING INSTRUCTIONS

001/... - 002/...

screw fixing

The instructions are valid for both cam switches with terminal protection class of IP20 and IP10

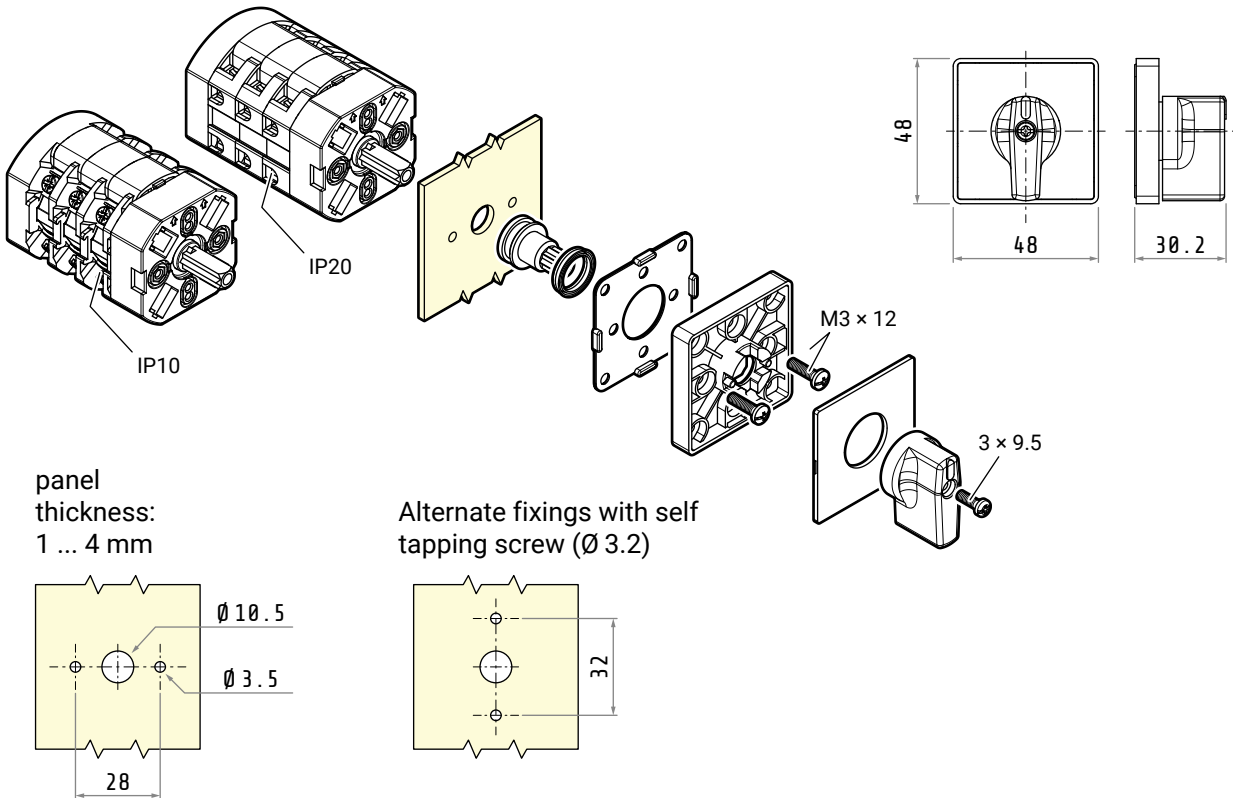

003/... - 004/...

screw fixing

The instructions are valid for both cam switches with terminal protection class of IP20 and IP10

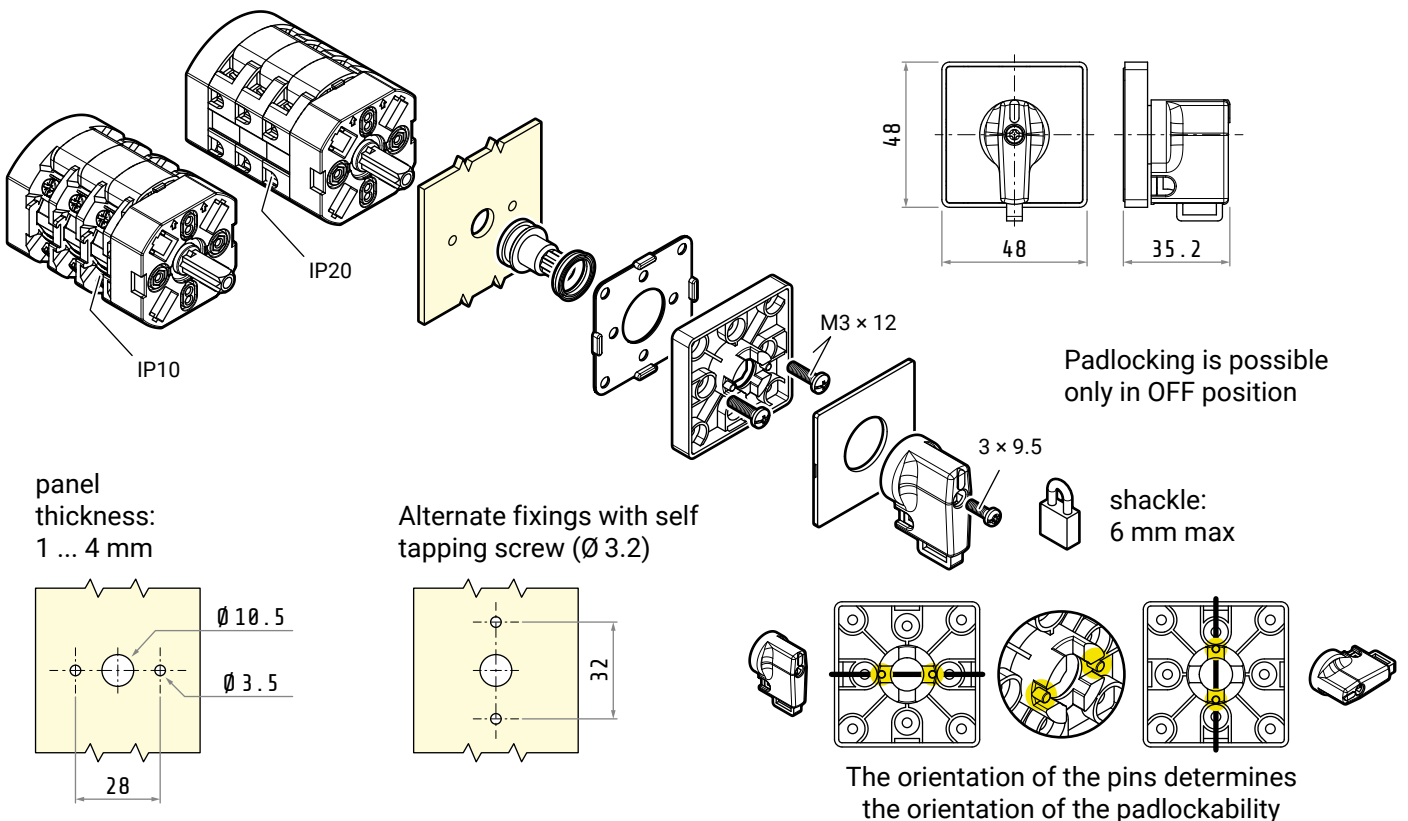

056X/... - 058X/...

Ø 22 fixing

The instructions are valid for both cam switches with terminal protection class of IP20 and IP10

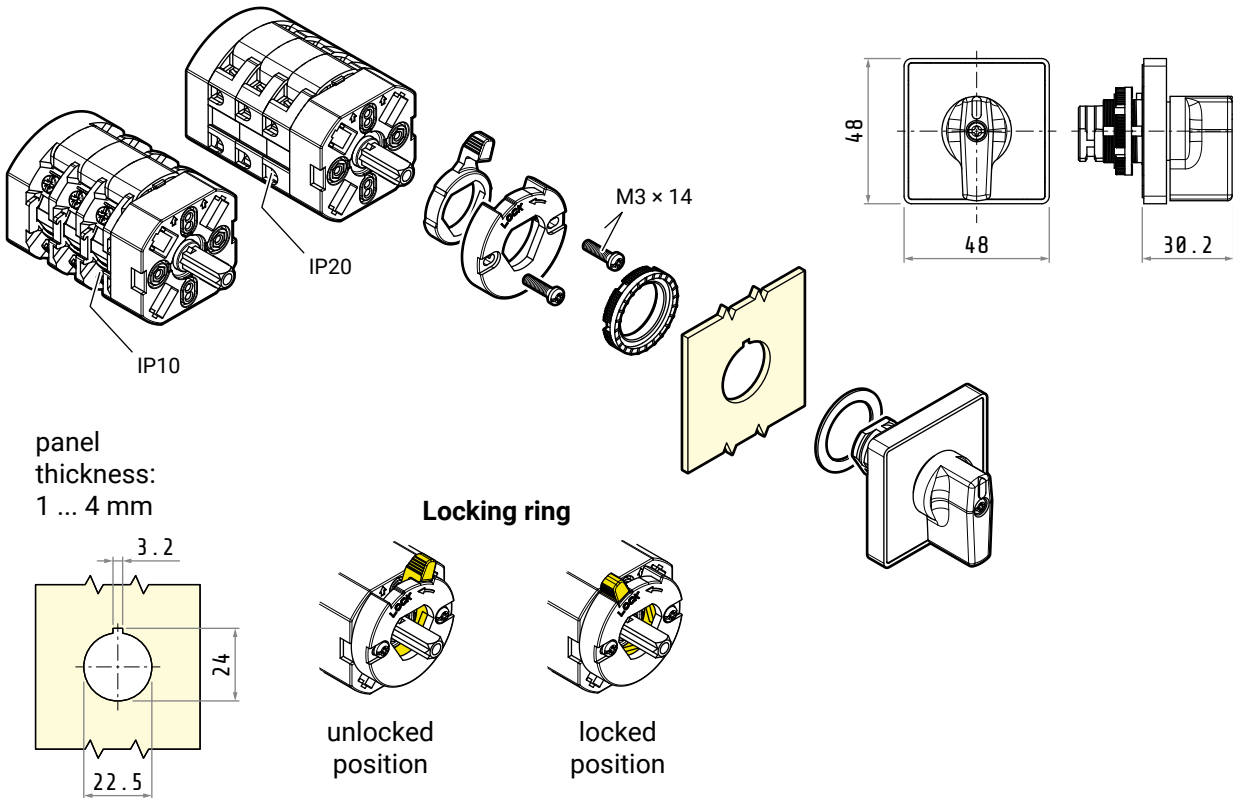

059X/... - 060X/...

Ø 22 fixing

The instructions are valid for both cam switches with terminal protection class of IP20 and IP10

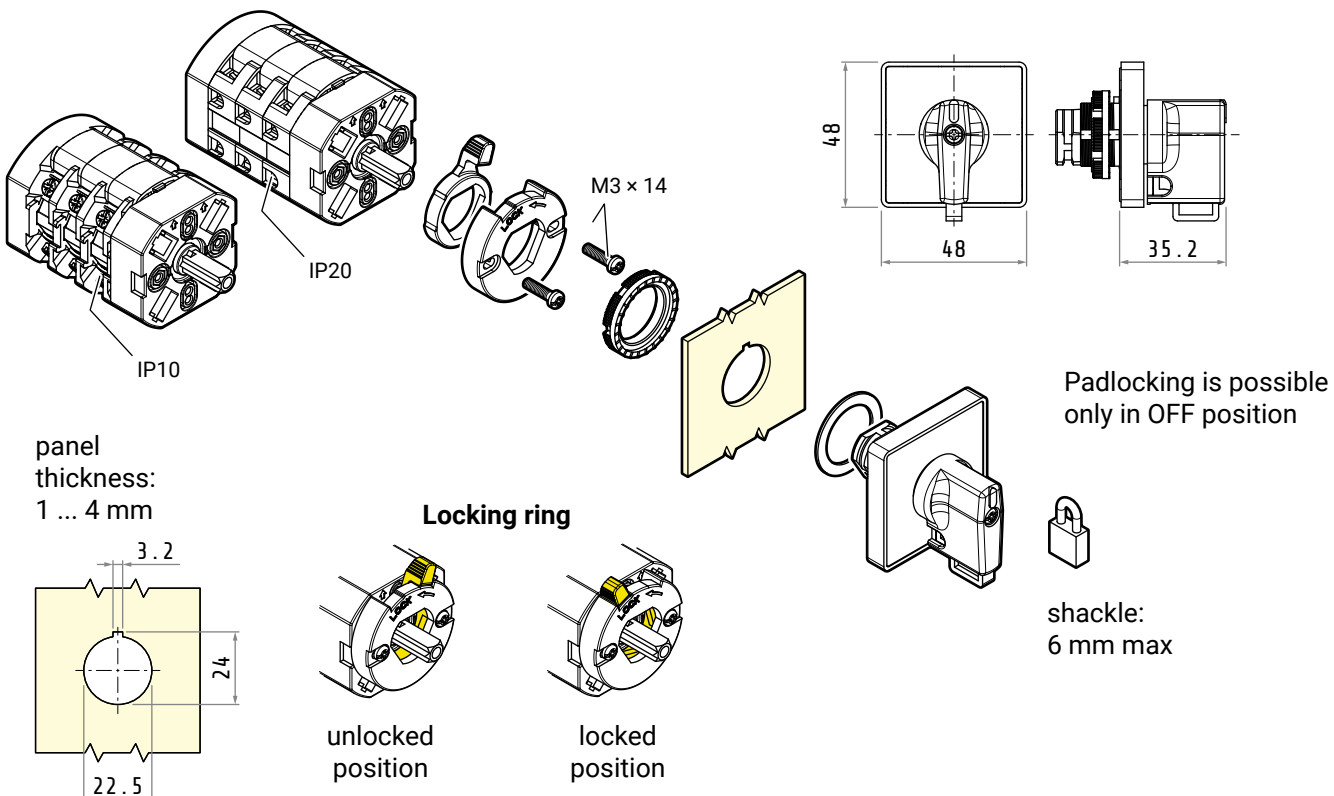

028X

Ø 22 fixing

The instructions are valid for both cam switches with terminal protection class of IP20 and IP10

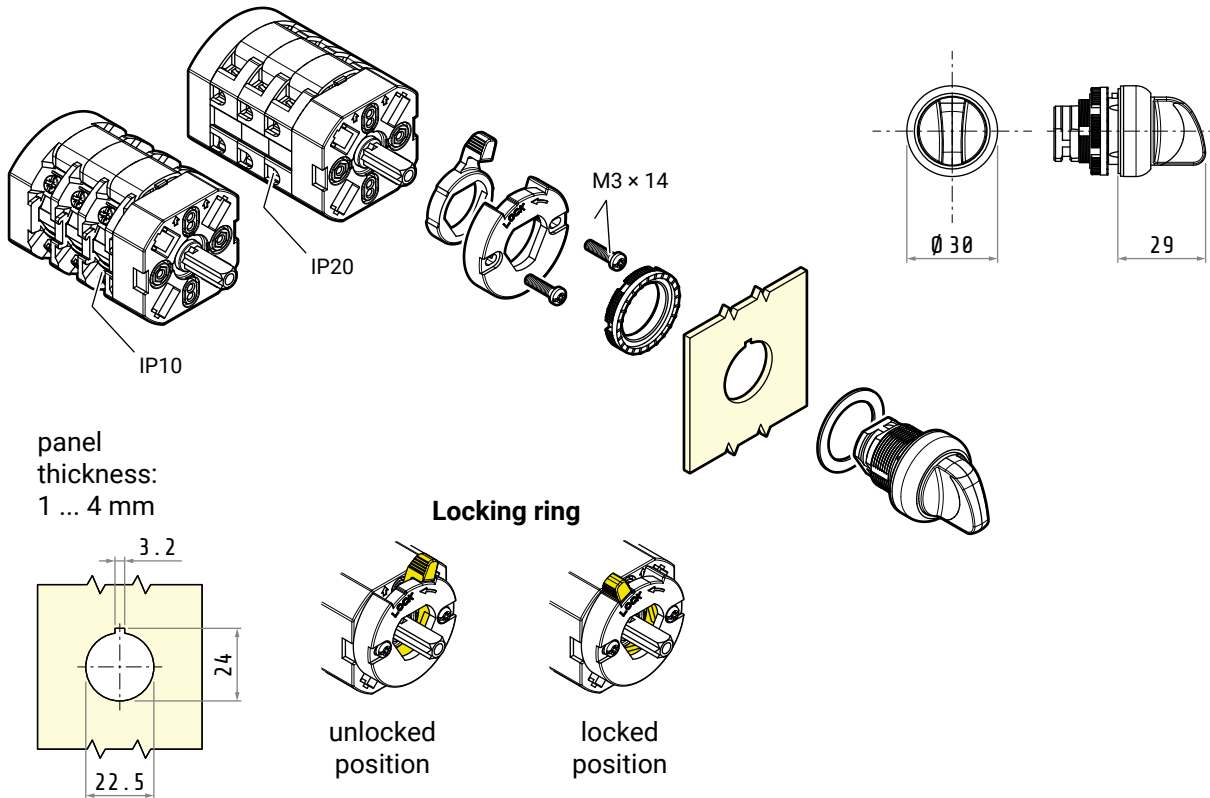

029X

Ø 22 fixing

The instructions are valid for both cam switches with terminal protection class of IP20 and IP10

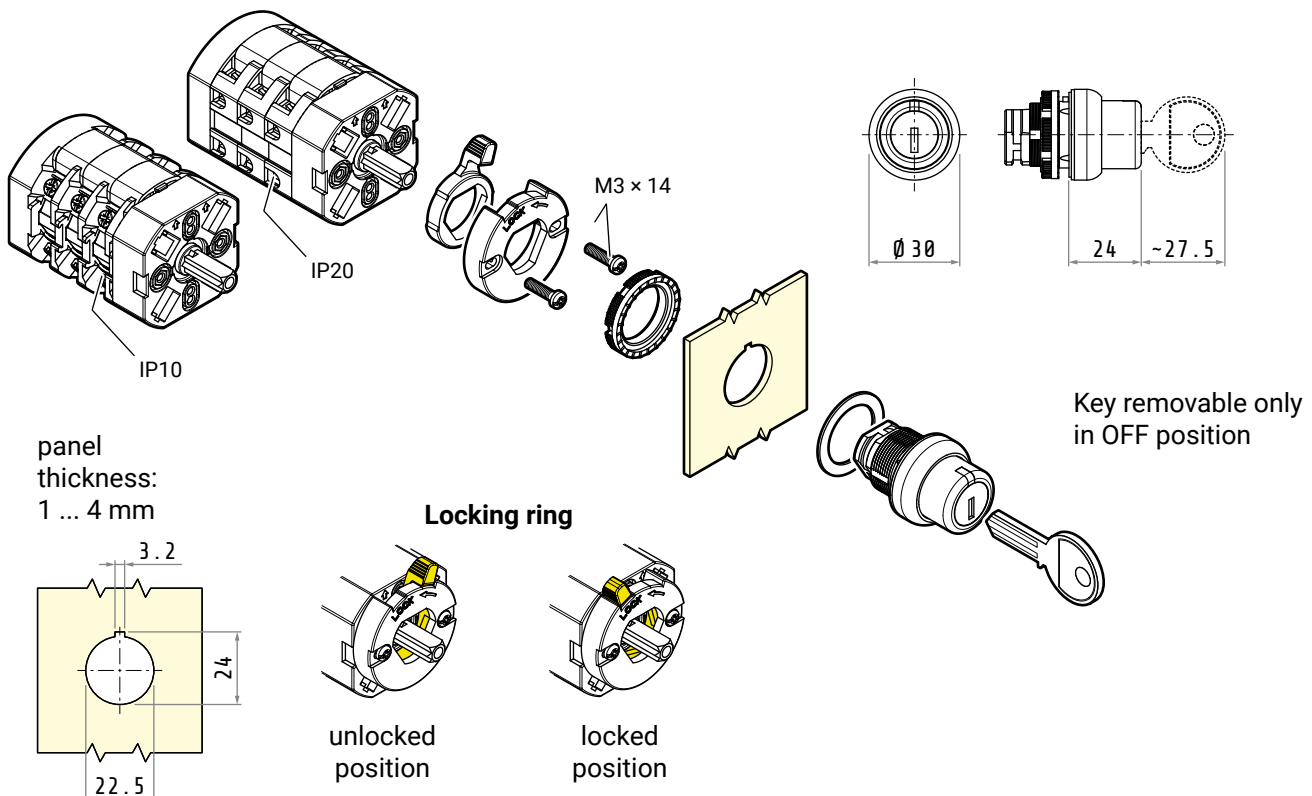

057X/...

Ø 22 fixing

The instructions are valid for both cam switches with terminal protection class of IP20 and IP10

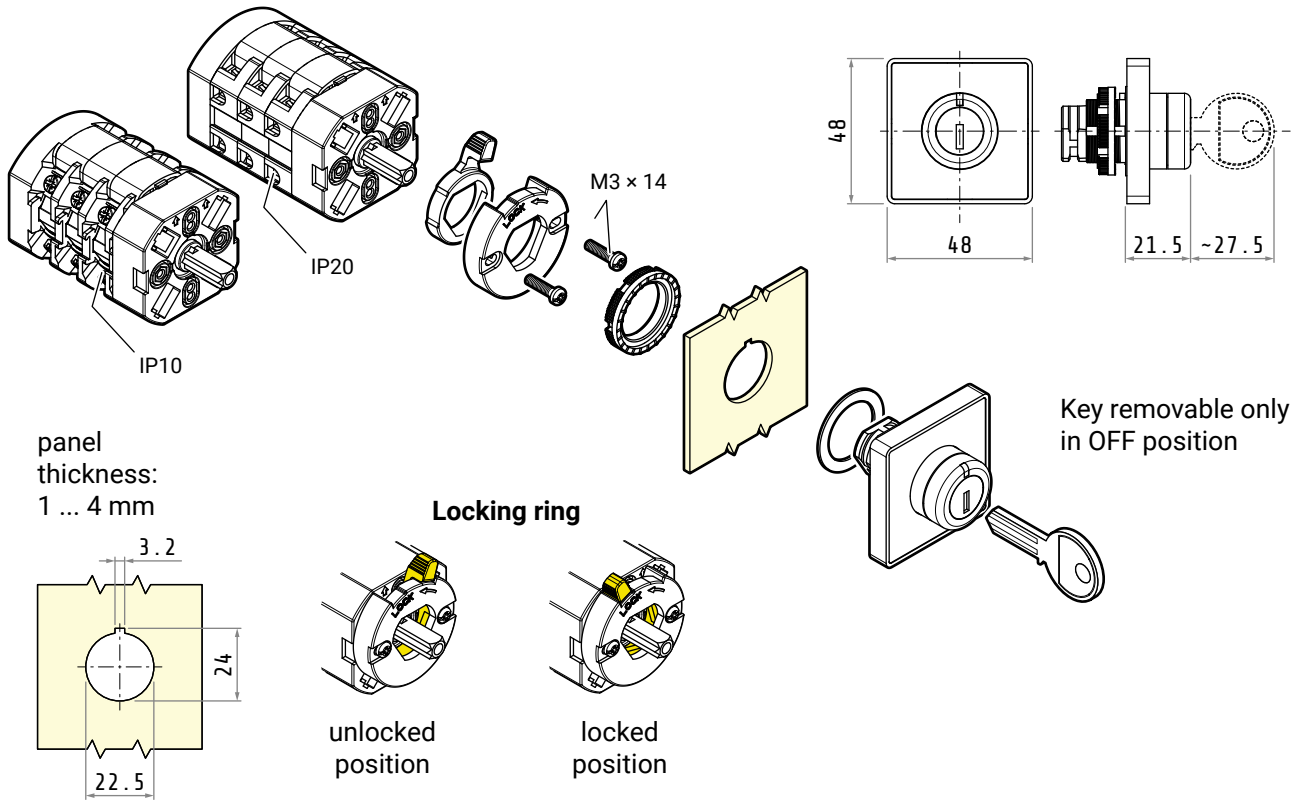

009/... - 010/...

screw fixing

The instructions are valid for both cam switches with terminal protection class of IP20 and IP10

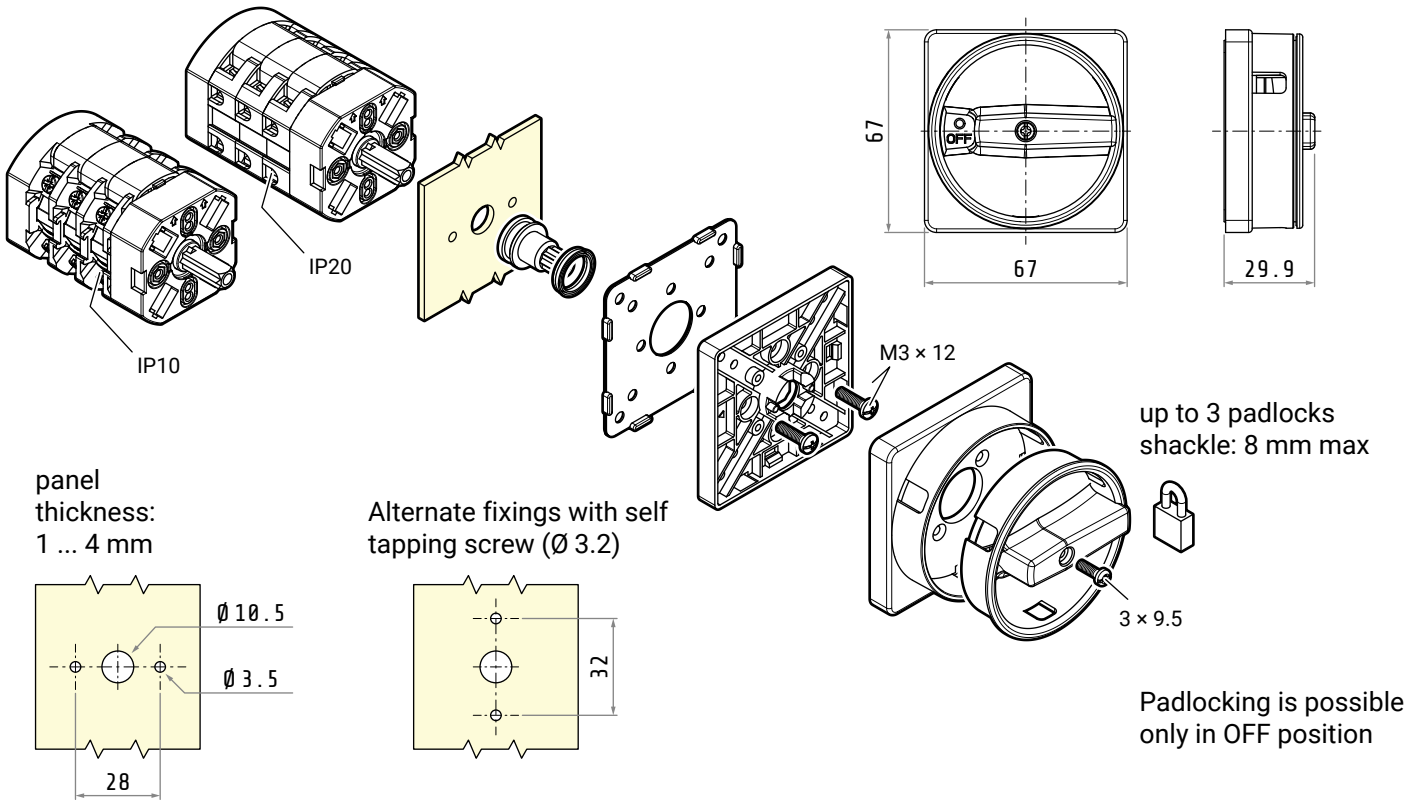

061X/... - 062X/...

Ø 22 fixing

The instructions are valid for both cam switches with terminal protection class of IP20 and IP10

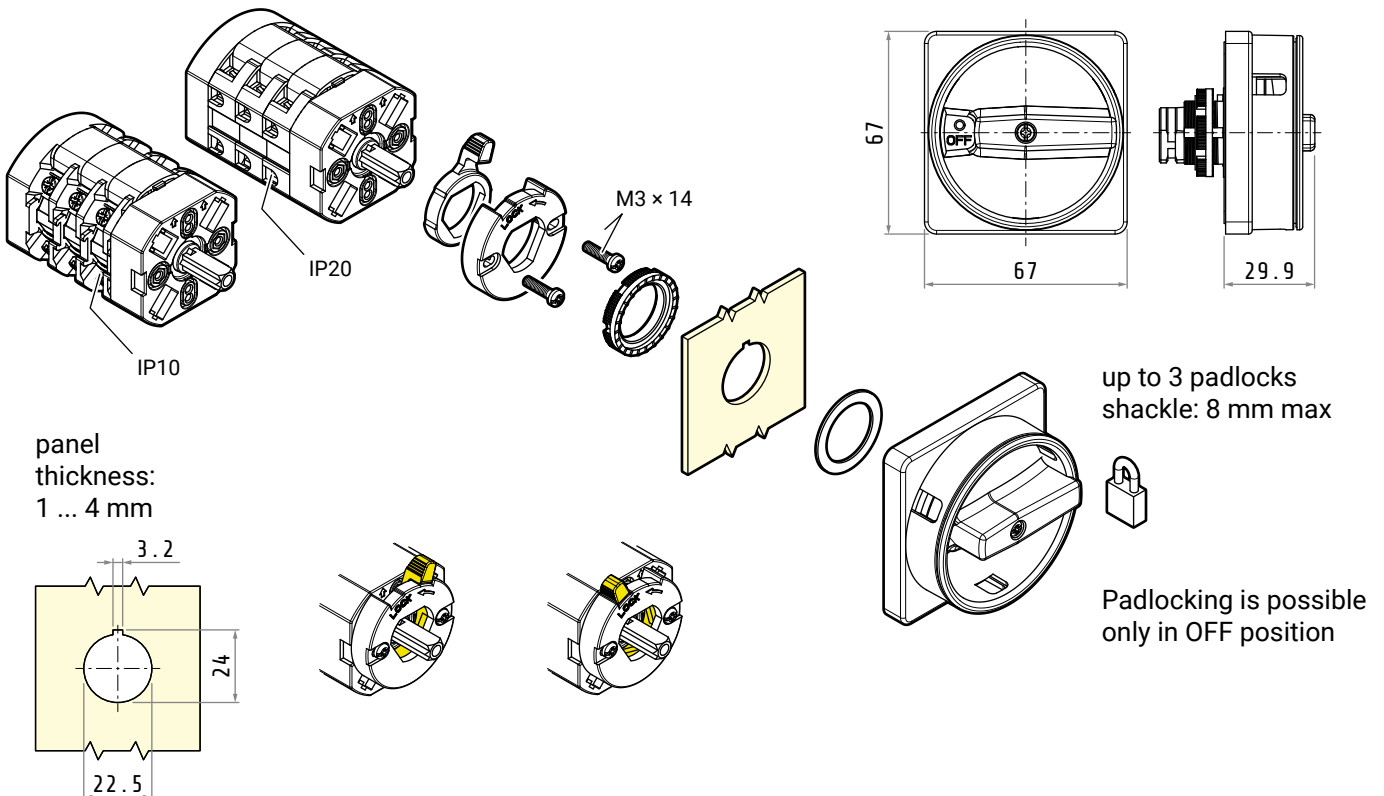



A series of horizontal dashed lines spanning the width of the page, providing a template for text entry.



A series of horizontal dashed lines spanning the width of the page, providing a template for text entry.



A series of horizontal dashed lines spanning the width of the page, providing a template for text entry.